

## NIST Traceable Portable Model 3425 Elemental & Oxidized Mercury Calibrator Rev. 062023

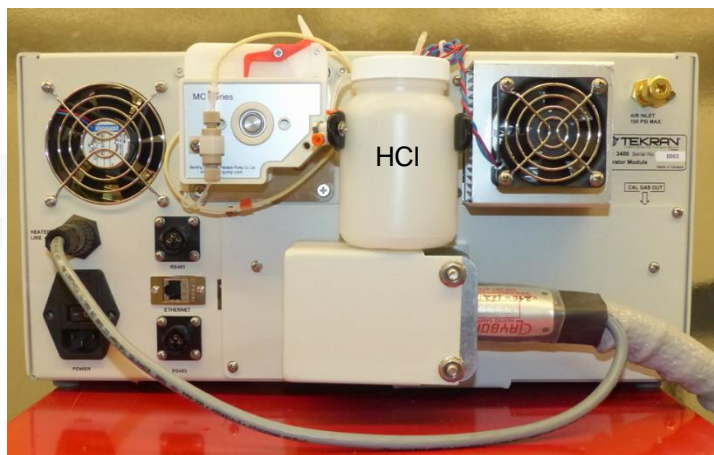

The Tekran® Model 3425 Elemental & Oxidized Mercury Calibrator provides NIST traceable calibration gas for system calibration. The 3425 is an added, programmable calibration gas source that complements the standard calibration gas source already installed inside the 3400 HgCEMS, necessary to comply with USEPA and other government regulations. It can be used as a stand-alone mercury source and calibration system for monitoring or control technology research. The 3425 can be set to automatically generate multi-point calibration gas. The 3425 delivers elemental mercury gas using a NIST traceable, temperature controlled, saturated mercury vapor source. It generates oxidized mercury using a patented method that reacts HCl with elemental mercury to produce gaseous  $\text{HgCl}_2$  for system calibration or converter efficiency evaluation. Precision mass flow controllers dilute the mercury source output to the desired value. The mercury generator is capable of continuously producing large flow rates of calibration gas at virtually no ongoing cost.

Unlike other saturated sources, the Model 3425 contains a host of advanced features providing superior accuracy and unattended, remote operation. The 3425 Mercury Calibrator connects to any manufacturer's external mercury analyzer, via a supplied 2-meter heated umbilical, enclosing a single 3/8-inch (9.5mm) Teflon tube, terminated with a SS compression fitting.

### Product Highlights

- Hg output range<sup>1</sup>: 0.5 to 300  $\mu\text{g}/\text{m}^3$
- Calibration gas delivery rate<sup>1</sup>: 4 to 20 SLPM
- Mercury source life: many years
- Allowable ambient temp: +5 to +45°C
- Hg source control range<sup>2</sup>: +4.00 to +30.00°C
- Independent linearization tables for each MFC

### Applications

- Coal fired power plant MATS monitoring
- Waste incinerator emissions
- Third party CEMS auditing
- Metrology labs
- Cement plant MACT compliance monitoring
- Bench scale testing
- Mercury removal process monitoring
- Laboratory & field research

## Principles of Operation

A Peltier heater/cooler maintains precise temperature control of the mercury reservoir. A mass flow controller, MFC-1, keeps precise and accurate carrier flow through the mercury chamber. The source exit flow is saturated with elemental mercury vapor and is then diluted by the flow from MFC-2. Solenoid valves isolate the source when mercury is not required and also select between two available output paths. The backpressure regulators provide the requisite inlet pressure (>45 PSI) to ensure proper nebulizer function and efficiency of the oxidizer block. The valve manifold is heated to minimize any condensation of mercury vapor in the undiluted portion of the flow path. Additional safety interlocks ensure the source is activated only when all temperatures are stable.

## 3425 Calibrator

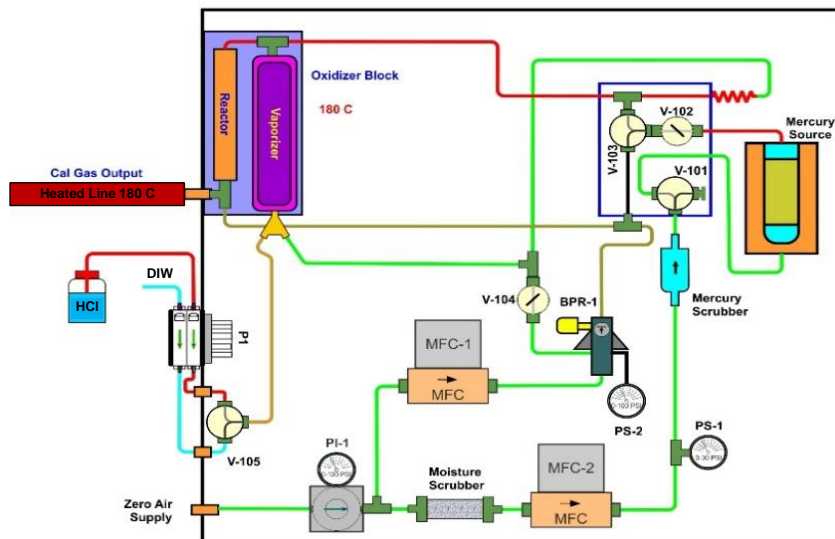

*Note: System requires a pressurized source of mercury-free zero air for proper performance. In-house pressurized air may be used if combined with the Tekran 1304-100 zero air scrubber unit.*

## Product Features

- Calibration gas output port
- High output rate: up to 20 SLPM
- Heated/cooled saturated mercury source
- Ultra-precise source control
  - Repeatability:  $\pm 0.02^{\circ}\text{C}$
  - Accuracy:  $\pm 0.05^{\circ}\text{C}$
  - Range<sup>2</sup>:  $+4.00$  to  $+30.00^{\circ}\text{C}$
- HCl reservoir and peristaltic pump located on back panel for easy access
- Precision pressure sensor for constant output concentration despite back pressure variations
- MFCs individually calibrated to minimize errors at low flow settings
  - Multi-point calibration tables
  - Linear interpolation between calibration points
- Solenoid valves provide control functions
  - Isolation of Hg source until safe to activate
  - Selection between main and auxiliary outputs

## Remote Control

For stand-alone applications, the HMI touchscreen is used to control the Model 3425 Elemental & Oxidized Mercury Calibrator.

- Readout and monitoring of all current temperatures, pressures and flows with alarms
- Setting of all temperatures and MFC set points
- Initiation of immediate or automatic calibration sequences
- Periodic temperature sensor and MFC recalibrations

***Due to ongoing development, all listed specifications are subject to change.***

<sup>1</sup> Standard Unit. Other working ranges are available. Not all output flow/concentration combinations are available simultaneously.

<sup>2</sup> Other temperature ranges available. Contact Tekran for details.