

Model 1100 Zero Air Generator

Rev 070920

The **Tekran® Model 1100 Zero Air Generator** allows the Model 2537 Mercury Vapor Analyzer to run without a separate pressurized zero air supply and regulator. Since most locations do not come equipped with an in-house source of pressurized air, this generator can eliminate the need for cylinders of Ultra High Purity (UHP) zero air. This is especially helpful for operation in remote locations or in applications requiring portability. The generator is housed in a compact case and weighs less than 10 pounds (4.5 kg). A carrying handle, allows easy transport.

The generator may be automatically controlled by the Status & Control connector located on the rear panel of the Model 2537. This allows the zero air generator to be activated only when the instrument requires zero air. The generator may also be manually switched or remotely controlled via a contact closure.



The generator is capable of generating in excess of 3 litres per minute of mercury-free air. This provides the capacity to supply two separate Tekran 2537 instruments with zero air, or one instrument plus auxiliary equipment requiring low-mercury air.

Applications

- Continuous monitoring
- Flux measurement
- Equipment Blanking
- Mobile Applications
- Mercury Generation & Dilution Apparatus
- Troubleshooting Diagnostics

Connection Diagram

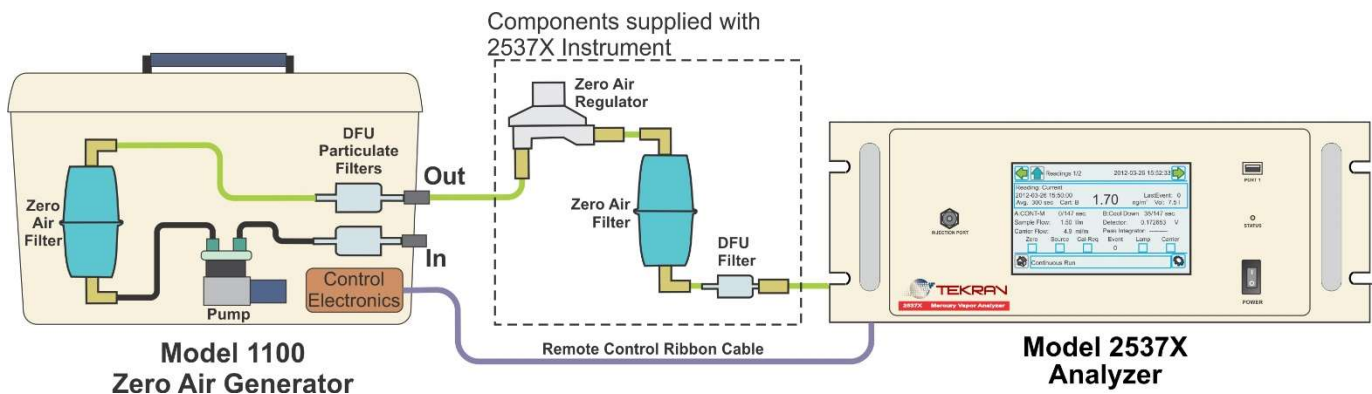

Principles of Operation

When activated, ambient air is drawn from the INLET fitting through a 0.1 um particulate (DFU) filter by the integral pump, and sent to a multi-component mercury scrubber. The cleaned air is then passed through another 0.1 um particulate filter before being sent to the OUTLET fitting. Under normal use, the mercury adsorbent is expected to last for more than a year before requiring replacement. Users may purchase a refill kit from Tekran when the zero air scrubbers require change-out.

If being used indoors, the INLET line is usually fed from outdoor air in order to reduce the incoming mercury levels and prolong the life of the adsorbent materials. The Model 1100 OUTLET is connected to the low pressure zero air regulator and the zero air canister supplied with the instrument.

The unit may be controlled in a number of ways.

- Manual AUTO / OFF / ON switch located on the generator.
- External cable connected to Model 2537 Status & Control connector. (Cable supplied)
 - External contact closure. (Through standard 2 conductor 1/8" mini phone jack.)

Output

Delivery Rate: > 3 lpm @ 1.5 PSI
Mercury Output: < 0.1 ng/m³ Hg⁰ typical
(Levels may be further reduced by using the additional scrubber)

Environmental

Ambient Temperature: 10 - 30 °C
Humidity: 10 - 95 % RH (Non condensing)
Altitude: 0 - 2000 m above msl.

Physical

Instrument Only		With Shipping Container	
Width:	14" (355 mm)	28"	(71 cm)
Height:	10" (255 mm)	16"	(41 cm)
Depth:	8.5" (215 mm)	18"	(46 cm)
Weight:	9.5 lb (4.5 kg)	16 lb.	(8 kg)

Power

115 VAC, 50 VA max. 50-60 Hz. (230 VAC available)

Ordering Information

The Model 1100 includes the following standard components:

- Power Cord
- Instrument Interface Cable (6 ft)
- User Manual
- Teflon[®] zero air line (1/4" dia, 5 ft. length)

Options

- **Opt. 002** Second instrument kit. Includes cabling, fittings and tubing required to allow one Model 1100 to supply two co-located Model 2537 analyzers.
- **Opt. 220** Power supply for 220-240 VAC operation. (Standard is 110-120 VAC)